

SETSIS Evolution

SETSIS Evolution
Working under corrosive atmospheres
Part 1: TG mode

Introduction

Working under corrosive atmospheres in TG mode or TG-DTA/DSC mode is always a delicate experimental operation as there is a high risk of damaging the metallic parts (thermocouples, detectors, crucibles, balance) of the system.

Different conditions need to be considered when a corrosive atmosphere is planned:

- the material under study emits corrosive vapours when decomposing. In this case, the vapours are diluted in the inert carrier gas and therefore risk of corrosion is limited to the crucible and the vicinity of the detector (DTA/DSC)
- the interaction between a material and a corrosive gas atmosphere is to be investigated. In this case the concentration of the corrosive gas is significantly higher as it can be used pure or diluted in an inert gas. Two further situations can be encountered: use in dry conditions or use in wet conditions. In both situations, the risk of corrosion in the system will depend on the type of gas, its concentration, its humidity and the temperature of the reaction.

As it is difficult to cover all types of experimentation under corrosive atmosphere, part 1 of this technical note will describe the experimental devices provided with the SETSIS Evolution system for such studies and the experimental solutions according to the type of gas for the TG mode operations.

Materials compatibility

In the TG mode, the sample is contained in a crucible (silica, alumina, platinum, tungsten or graphite) suspended from the balance using a suspension. Different types of suspensions (silica, platinum, tungsten, graphite) are available according to the temperature range.



Figure 1
 The TG mode with suspensions and crucibles

Instrument
SETSIS Evolution
(RT to 2400°C)



In the case of emission of corrosive gas from the sample decomposition, each material has different limitations:

Silica is used for the crucible and the suspension. It is very stable versus any dry corrosive gas. In the case of humid gas, caution has to be taken if fluorine is emitted as silica is sensitive to HF. The main disadvantage of silica is its limitation in temperature of use at 1000°C

Platinum, as a metal, is very convenient for applications at high temperature (up to 1750°C) under inert and oxidising gases. It is used for the crucible, the suspension and also the thermocouples combined with Rhodium. However it is very sensitive to different types of gases and vapours.

•Metallic vapour

Among the metals, silicon (Si) is one of the most problematic as it is contained in silica (SiO_2), SiC. The problem occurs especially above 1000°C. Among the other classical platinum poisons, it can be noticed phosphorus (P), sulphur (S) coming from sulphides, lead (Pb), but also B, Zn, Sn, Ag, Au, Li, Na, K, Sb, Bi, Ni, Fe, As. In any case it is recommended to consider the corresponding phase diagram of Pt with the metal from the emitted vapour and check if there is a risk of eutectic formation. Here below the Pt-Si diagram (Figure 2). One way to prevent direct contact between the crucible and the metallic vapour, is to have the sample embedded in alumina powder

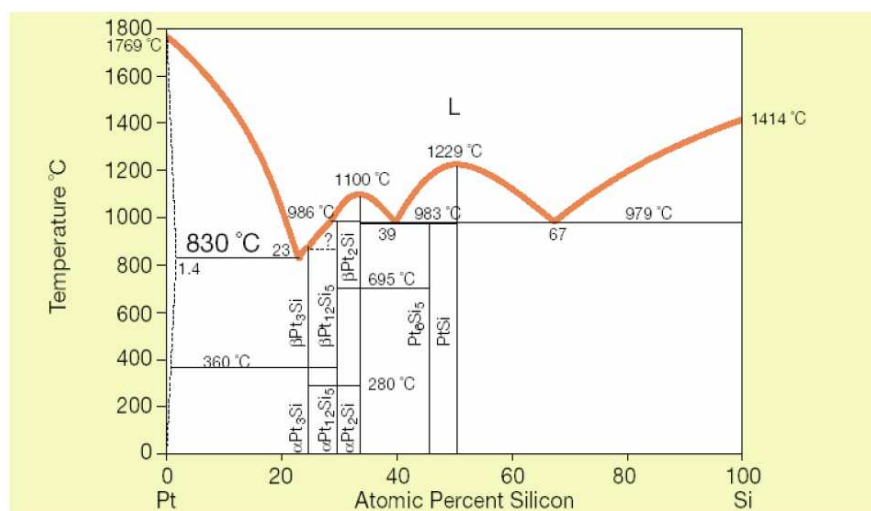

Figure 2: Pt-Si phase diagram

•Hydrogen

Platinum is also very sensitive to hydrogen above 1000°C. It is observed that the wires of the PtRh thermocouples become brittle and break.

•Oxygen

Platinum is very stable in oxidative atmosphere up to high temperature. However a thin oxide layer will form at high temperature on the Pt suspension and crucible. In the case of measurement of very weak mass variations, this deposit will affect the TG result.

•Other gases

Platinum is also stable in CO_2 . But it will react with CO , SO_2 , H_2S , chlorine. In general, platinum is not recommended to be used in reducing atmospheres

Alumina, as a ceramic oxide, is highly suited for applications at high temperature (up to 1750°C) under inert and oxidising but has some limitations in reducing atmospheres. It is used for the crucible but also for the furnace inner tube and the thermocouple rods. However it is sensitive to some types of gases and vapours.

- **Hydrogen**

Hydrogen is considered to be inert versus alumina on a very large range of temperature. However at high temperature, a reduction of traces of oxides (especially SiO₂) in alumina can be observed.

- **Carboneous atmospheres (CO, CH₄)**

CO and CH₄ are considered as reducing atmosphere. In the literature (*Halmann and al., Energy 32 (2007) 2420–2427*), it is reported that the reduction of alumina with CH₄ may occur from 1500°C.

Graphite is a very convenient material for very high temperature (up to 2400°C) but only under inert atmosphere. However nitrogen is not recommended as there is a risk of formation of cyanide.

Tungsten is also dedicated to applications at very high temperature (up to 2400°C) under inert atmosphere. Oxidative atmospheres have to be forbidden. It is used for the crucible, the suspension and also the thermocouples combined with Rhenium.

- **Hydrogen**

Tungsten is very well adapted for investigation in hydrogen atmosphere when platinum can not be used (above 1000°C). For such a test, tungsten will be used for the crucible, the suspension and the thermocouple

Solutions to work under corrosive atmospheres in TG mode

Dependent upon the test limitations described previously, different options are available to solve most of problems.

Silica tube (upper limit: 1000°C)

For experimentation under corrosive atmospheres up to 1000°C, a dedicated silica tube is introduced in the furnace. The lower part of the tube has a smaller diameter to enable the control temperature thermocouple to remain in the furnace chamber and out of the silica chamber (Figure 3). The principle is to introduce the corrosive gas at the bottom part of the furnace, the outlet being at the top of the furnace.

An inert gas is introduced inside the balance in order to protect the weighing module.

With such a system it is possible to work only in TG mode. As the temperature control thermocouple is outside the silica tube, there is no contact between the thermocouple and the corrosive gas.

The suspension and crucible are also to be selected in silica.

With such an arrangement, it is possible to run TG experiments under safe conditions with any type of corrosive gas. Caution only has to be observed with fluorine, especially in wet conditions.



Figure 3
Cross section of the
silica tube arrangement

Sapphire suspension and crucible (upper limit: 1000°C)

For experiments under corrosive atmosphere above 1000°C, sapphire is used as an inert material to produce a dedicated hanging. Sapphire combines unique properties for such applications: high chemical resistance, high thermal stability, null porosity, very good heat transmission. According to these specific characteristics, sapphire will resist in most of the corrosive atmospheres.



Figure 4: Picture of the sapphire attachment (crucible+suspension)

The sapphire device is made of a sapphire rod acting as a suspension, mechanically combined through a sapphire clamp to a crucible (Figure 4). In the upper part, a platinum suspension is used for the hanging to the balance beam (Figure 5). The sapphire suspension and crucible are designed to work up to 1750°C in any reducing and oxidizing atmospheres. In the same time, the temperature control thermocouple has to be selected in accordance with the atmosphere and the metallic parts need to be protected.

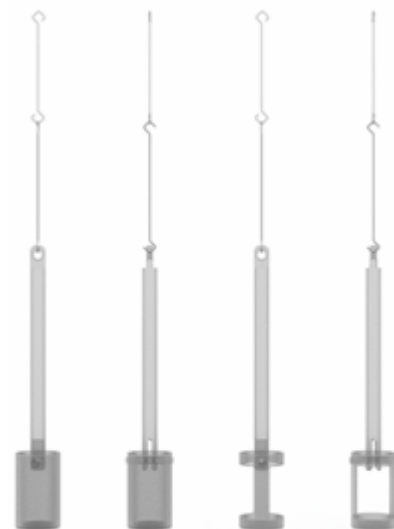

Figure 5: Description of the sapphire attachment

Solutions to work under fluorine atmospheres in TG mode

The SETSYS Evolution TGA, with some modifications, can be used to work in dry HF and F₂ atmosphere. Operations with a concentration of HF up to 1% maximum and at temperatures up to 1000°C are available.

The aluminium parts of furnace have to be replaced by stainless steel elements. All the gaskets used in the furnace need to be in Kalrez (very resistant to fluorine) (Figure 6).

A K (Chromel-Alumel) type - 1100°C thermocouple with inconel lining has to be used for the temperature control (Figure 7). This type of thermocouple is very stable in oxidizing atmosphere up to 1300°C.

Inconel is also used to produce the suspensions and the handle to suspend the alumina crucible that has to be used in the fluorine atmosphere.

In order to avoid the HF condensation (20°C at atmospheric pressure), the whole water jacket of the furnace, as well as the inlet/outlet, must be heated with hot water at 60°C (80°C max.) through a thermostated bath. The balance is protected by a helium (lighter than HF) circulation and the HF is introduced from the bottom of the furnace. The gas exhaust is performed at the top of the furnace. Any trace of water has to be avoided in the furnace to prevent the formation of hydrofluoric acid that will corrode the metallic parts of the instrument, especially the balance.

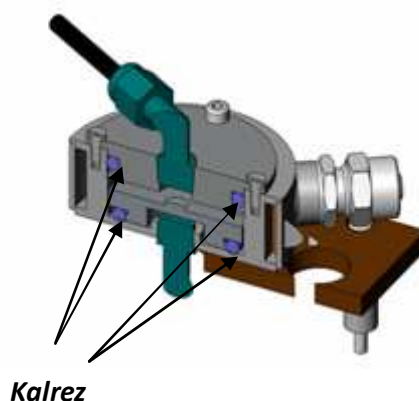

Figure 6
Kalrez gasket of the thermostated check valve

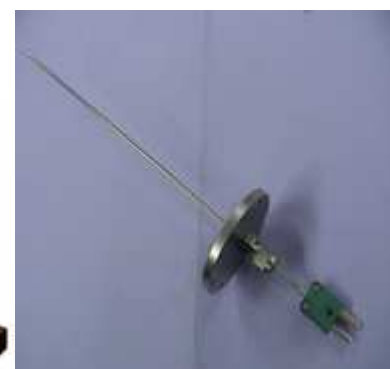

Figure 7
K type thermocouple with inconel lining, crimped on the flange

Gas compatibility table

The following table gives a brief summary of the compatibility of the main parts of the thermogravimetric analyzer according to the most uses gas.

The table considers the following parts:

- The crucible
- The inner tube in the furnace defining the experimental chamber
- The suspension to hang the crucible to the balance
- The temperature control (T/C) thermocouple

	Tube / crucible			Suspension / crucible			Thermocouple			
	Al2O3	Vitreous carbon / Graphite	Silica	Sapphire	Platinum	Tungsten	Platinel	Pt/ Pt-Rh10%	Pt-Rh6% / Pt-Rh30%	W5
Inert	1750°C	2400°C	1000°C	1900°C	1750°C	2400°C	1000°C	1600°C	1750°C	2400°C
Reducing										
H₂	1750°C	600°C	1000°C	1750°C	1000°C	2400°C	1000°C	1000°C	1000°C	2400°C
CO	1750°C	600°C	1000°C		1000°C	NA	1000°C	1000°C	1000°C	NA
Oxydative										
Air	1750°C	NA	1000°C	1750°C	1750°C	NA	1000°C	1600°C	1750°C	NA
O₂	1750°C	NA	1000°C	1750°C	1750°C	NA	1000°C	1600°C	1750°C	NA
CO₂	1750°C	700°C	1000°C		400°C		400°C	400°C	400°C	

NA: not applicable

In Part 2, the work under corrosive gas in the TG-DTA/DSC mode will be presented.

Instrument
SETSYS Evolution
(RT to 2400°C)



TN679 - 5/5

www.setaram.com – sales@setaram.com

